



RETURNED CRATE CHECK



HEUFT LGX



A good start



A good crate check is indispensable for an efficient bottle flow. Incorrect bottles or cases entering production become a real cost factor in view of the growing variety of brands. It pays off to sort out the wrong material with a returned case inspection. The HEUFT LGX is the ideal solution for this.

This control system not only examines the crate with a fine-tooth comb but also its

contents. The majority detection controls the maximum share of foreign bottles.

In this way the HEUFT LGX not only saves costs but makes a considerable contribution to a smooth production process.

A good start - the HEUFT crate check.



Handgrip check

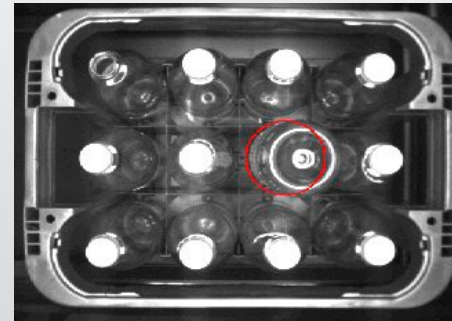

Top-down bottle

Incident light gives insight



A crate can be clearly characterised when looking into it from above. The bottles in it can be seen, foreign objects or top-down bottles found and a broken handgrip area identified.

The HEUFT *LGX* works in a similar way: image processing software analyses the photograph taken from above in the same way as the human eye sends the

information it has recorded to the brain for processing.

The compartments are examined and foreign objects, top-down and lying bottles accurately detected. This ensures the unpacking suitability of the case. A handgrip area which is damaged or missing can impair the smooth process and safety - during production and at the

consumer's. The HEUFT *LGX* reliably detects them and removes the crates in question from running production.



Close-up on closures



The variety of brands is constantly increasing and one's own empties are being increasingly mixed up with the containers from other bottling plants. A returned crate check has to do a good job in this respect and separate the bottles according to different criteria.

Neck rings, closure logos and bottle shapes provide decisive information for identification purposes.

Even the detection of different types of clip-lock bottles is possible - no matter whether the closures are open or on the bottle.

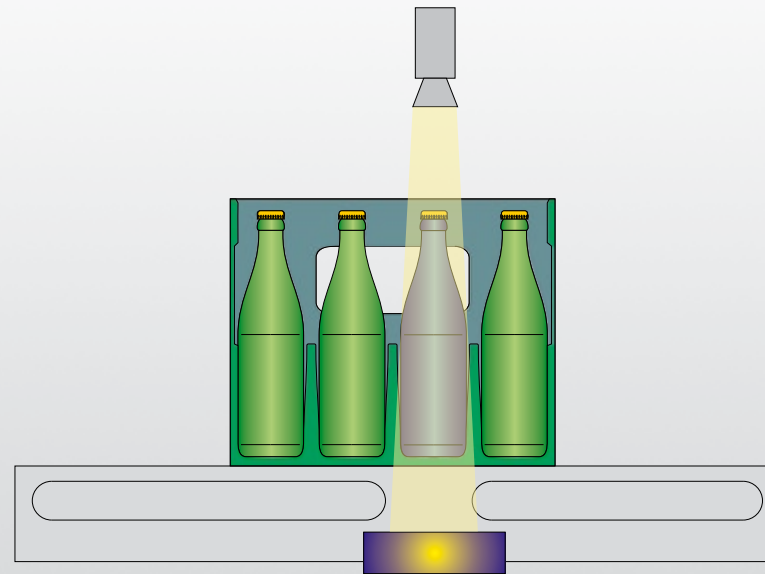

Bottle colour detection



When the proportion of foreign bottles is too high the production process is obstructed or even unwanted production stops occur.

A returned crate check has to prevent too many incorrect containers entering the bottle transport and being sorted by the bottle sorting unit or empty bottle inspection first in order to avoid bottle-necks and efficiency losses.

The colour of the bottle is not only important for the image of a product but is also decisive for how long it keeps. Therefore incorrectly coloured bottles have no business being in the current production - the HEUFT LGX helps to reduce their numbers right from the start. The crate is illuminated from below and a camera attached above the crate takes a photograph which it transfers to the image processing

software for evaluating. This determines how many bottles have a different colour and decides whether the crate should be rejected on the basis of preset parameters.

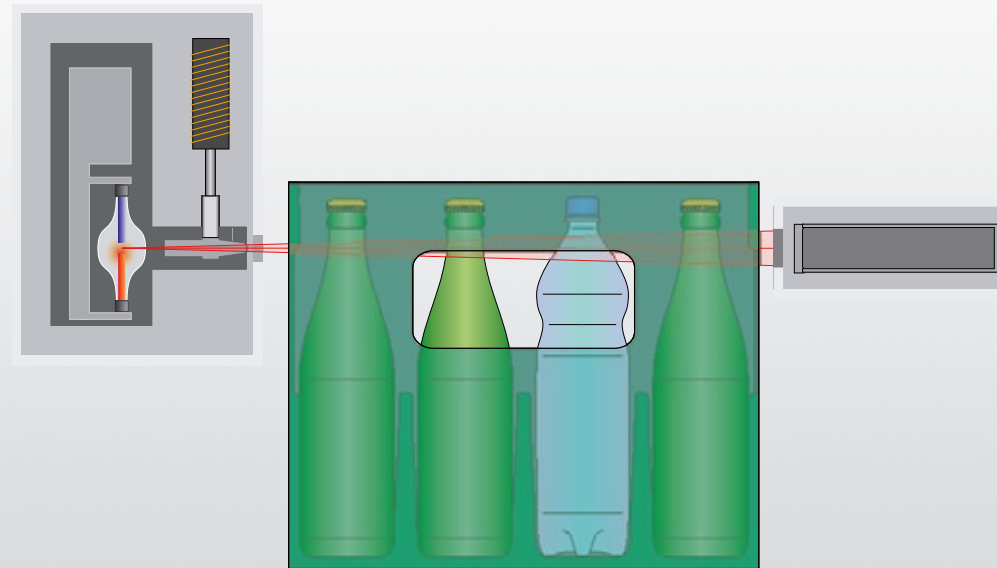

Knowing what is going on - the X-ray check



Crates enter the returned crate check again and again with thoroughly mixed up contents - glass as well as PET bottles. A device is needed which knows what is going on in order to reliably detect these - the HEUFT *LGX* does.

The crate is examined by means of X-rays. The values are measured in the neck area of the bottle so that any

contents which may remain do not falsify the result. The device then compares the measuring results with the values which are usual for this crate. A deviation between the radiation absorbed and the reference values indicates that the contents of the crate are mixed up.

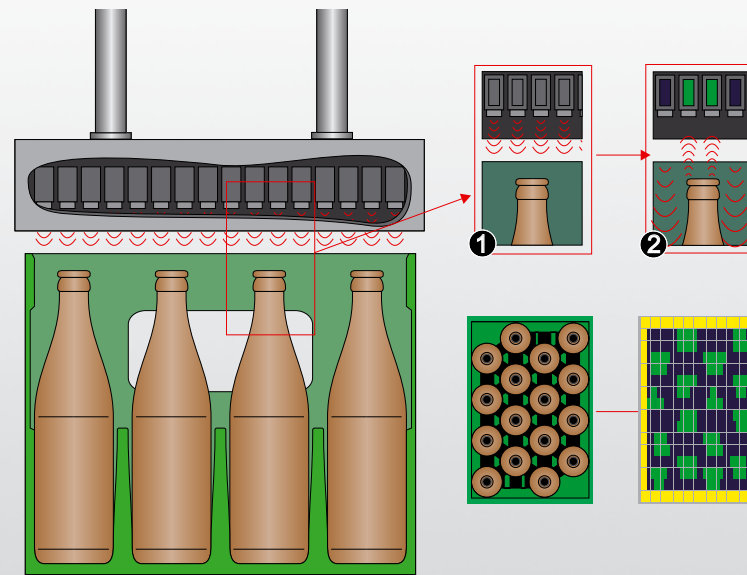

You cannot be too careful: detecting the bottle height by means of ultrasonics



Out of shape crates, foreign objects under the container, broken or deformed bottles: the most varied factors result in variations in the height proportions in a crate.

That is why the HEUFT LGX creates a height profile of the crate using an ultrasonic measurement. For this it emits ultrasonic signals. Special sensors

evaluate their reflections. The result: a clear picture regarding the height proportions in a crate.

The 16 integrated ultrasonic sensors do not have to be adjusted according to the brand each time: the HEUFT returned crate check is so flexible that it can inspect the most varied crates and evaluate them almost completely.

The risk of overseeing something important is therefore virtually excluded. Safety simply takes precedence.

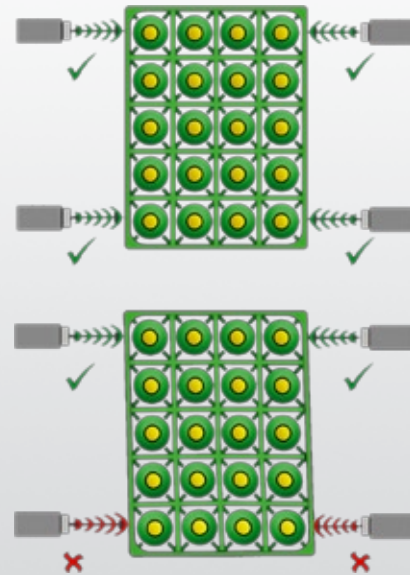

Measuring the diagonals of the crate



Corners - is the geometry of the crate correct?

It is necessary to sort out incorrect or faulty crates in good time in order not to disturb the production flow. The HEUFT LGX can clearly identify which crate is and which is not suitable for the current production by means of the geometry.

The device identifies out of shape drinks crates, where removing all the bottles

is no longer guaranteed, by measuring the lengths of the diagonals.

At the same time sensors examine basic characteristics such as the length, width and height of the crate. The crate does not enter production if these features differ from the reference values.

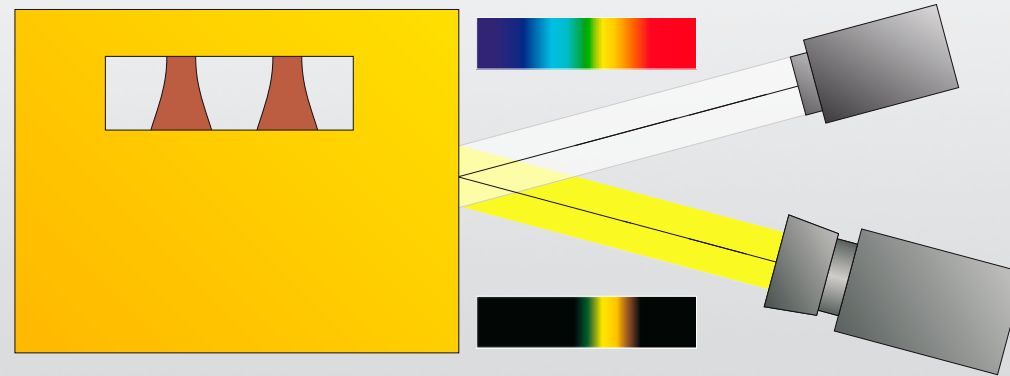

Crate colour and crate logo



More and more bottling plants also differentiate their products by using different crates. The multitude of colours and logos make checking the returned crate particularly demanding - this is not a problem for the HEUFT LGX.

Its own camera photographs the relevant area. The HEUFT *reflexx*, an image processing system developed by HEUFT, evaluates the photograph by comparing it to a preset reference sample - in real time of course.



A sidewall inspection capable of learning



Those wishing to check the crate walls for a multitude of quality features and at the same time determine themselves which deviations are and which are not tolerable should opt for a sidewall inspection which can be optionally integrated. Because it lets the operator make the decision on how he evaluates an identified object on the high-resolution, undistorted colour pictures each of which show a complete wall of the empty case. He can decide himself using the touchscreen whether it is an integral part of the crate design, an acceptable

anomaly or an unwanted fault. The technology determines potential faults for this based on different attributes such as size and texture and marks them independently on the HEUFT *PILOT* graphical user interface. The highlighted characteristics can be specifically selected in order to clearly characterise them by tapping on them. Another tap is all that is required and the decision is made to reject in the case of an unwanted object. This not only applies to this case but to all crates with such features. Because the HEUFT *LGX* remembers them permanently.

Whether logo faults, contamination, scratches, label remains, unreadable lettering, cracks, holes or damaged handles: faults which have been taught in once remain in the system and all the crates in question are consistently rejected from this time on. Positive objects can also be taught in. It is also possible to change the evaluations afterwards at any time. The case in question is rejected to be on the safe side if deviations are identified which have not been assessed yet. The final decision then lies with the operator again.

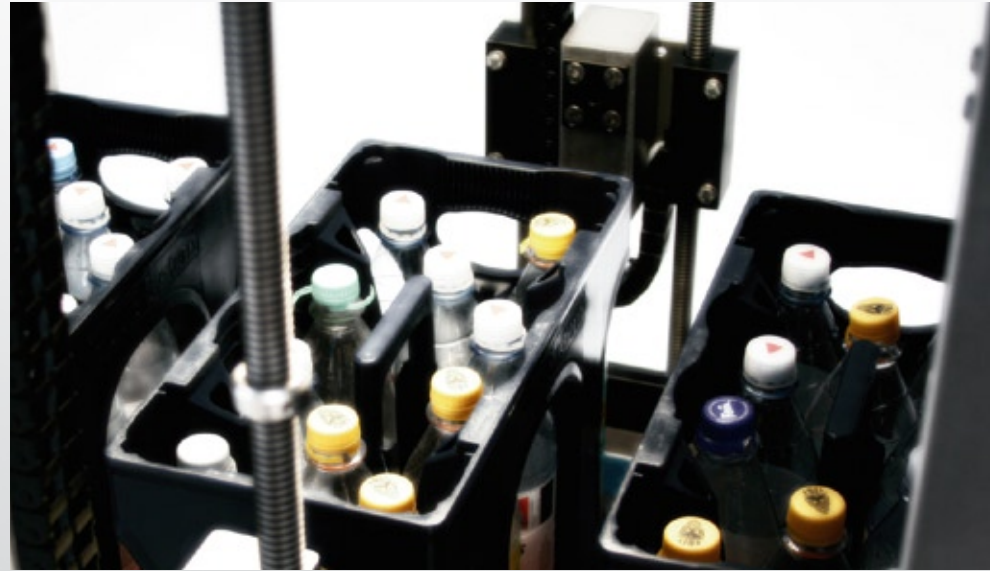

Maintenance and design



Easy operation, clear lines, minimum space required and almost maintenance-free: this describes the HEUFT LGX.

Brand changeovers are automatic: parameters are adapted, the heights adjusted and the sensors aligned by motor. This not only avoids faulty inputs but saves time and as a result real money.

All the components of the returned crate inspection are easily accessible and extremely hardwearing. Its design makes it easy to clean and ensures a long service life.

Its open construction facilitates intervention: all areas of the machine are accessible without the use of tools. Its

modular construction makes it possible to retrofit additional detection modules at any time and to keep the technology up to date.



Specifications

The HEUFT *LGX* offers an optimal fault detection with a minimum false rejection rate. Thus the following faults are detected in a 0.75 l GdB (Association of German Mineral Water Producers) crate with glass bottles:

- top-down bottles
- foreign objects e.g. foil, paper, string etc.

- bottles of the most varied colours
- foreign bottles
- deviating crate colour
- non-brand logos

An automatic test log checks whether the HEUFT *LGX* is completely operational. Therefore deviations are identified in good time and possible maintenance tasks can be planned in time.



Your cost advantages with HEUFT



We do everything in order to combine the very highest quality with fair prices:

- increased efficiency due to low foreign bottle quota during the bottle transport
- a reliable rejection process protects the subsequent machines
- maximum detection reliability with a minimum false rejection rate
- fully automatic brand changeover
- all the components have a high quality rating
- minimum amount of space required
- cost-cutting due to reduced downtimes and ensuring the production flow
- simple upgrading and converting due to a modular construction based on the HEUFT *SPECTRUM* basic system
- low wear and tear
- low failure rates
- shorter downtimes
- fast trouble shooting
- minimum operation necessary
- short maintenance times
- cost savings due to the HEUFT *TeleService*: a service technician does not need to be specially called out

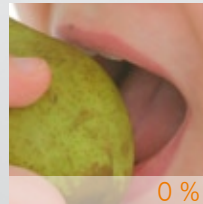
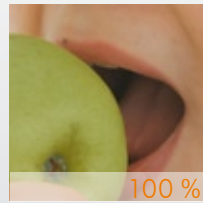
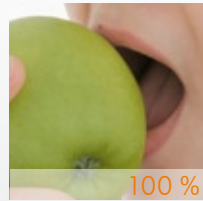

Easy for the human to differentiate

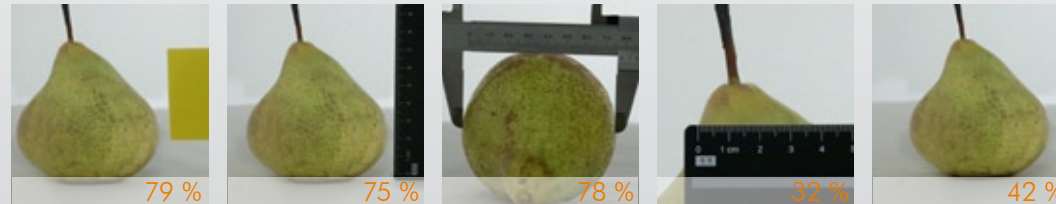
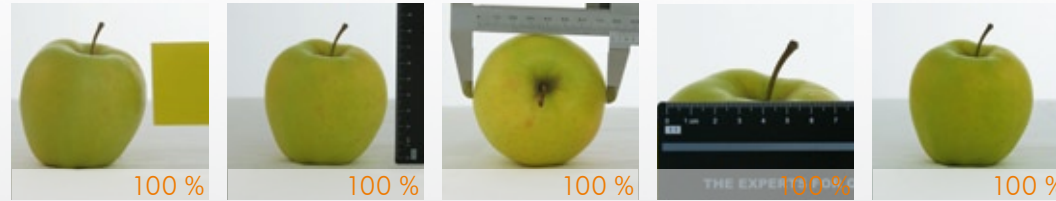

Colour Height Width Neck diameter Result

Reference

Good product

Fault

We compare apples with pears:

Although the small apple comes off worse than the pear in three out of four detections it is passed for production. Each detection may contribute a maximum of 80% to the result. This ensures that individual results do not affect the total result too much.

All containers with values less than 50% are considered to be faulty and have to be rejected.

It is easier for the human: he can quickly differentiate between an apple and a pear by taking a courageous bite.

What is fuzzy logic anyway?



Different detection methods are necessary in order to make a decision regarding the usability of a container or crate. However some cannot be clear - therefore the results have to be combined. And that is exactly what the fuzzy logic does. It uses probabilities and not absolute values for its calculations.

This means the following for each detection: how likely is it that the current con-

tainer corresponds to the desired one? This value expressed as a percentage is saved. A total probability is calculated from the probability values calculated using a complex algorithm upon completion of all the measurements. This states by how many percent the current container corresponds to the requirements.

Containers can also be incorporated by means of these calculation methods with

attributes which may be marginal but they nevertheless belong to the current production.



Networking



- integrated Ethernet interfaces as well as TCP/IP access to all networks
- connection capability to a pre-configured DDE interface and SQL database
- the HEUFT *PILOT* graphical user surface with a comprehensible menu structure for easy operating
- operation possible either via jog shuttle or touchscreen on the TFT screen at the device or via a network
- automatic transfer of counter readings or fault messages by SMS to a mobile phone or by e-mail if required
- firewall protected connection to the remote service by Ethernet – the HEUFT *TeleService* can access the line directly and rectify faults at short notice by means of remote diagnosis if the customer wishes

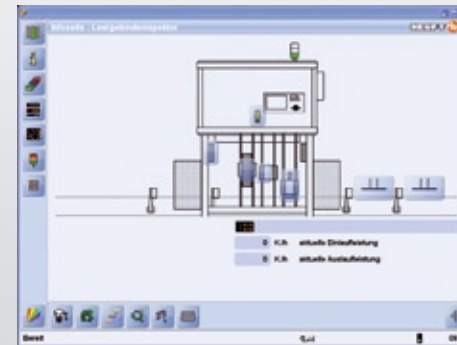

The HEUFT PILOT



- multilingual, simply arranged, comprehensible menu structure with extensive help boxes and complete online user's manual - the operating surface can be supplied in any language / graphic characters if required
- password-protected operator levels, can be adjusted to suit the tasks

of the operating staff, the quality assurance department etc.

- easy identification of spare parts with online and offline spare parts list with photographs and exploded views - the device sends the order either to an internal purchasing department or directly to HEUFT

- the operator receives all the information during a brand changeover regarding the necessary steps in order to exclude possible operating errors
- clear fault messages with service notes and support in order to avoid downtimes



The HEUFT *maxi-laner*

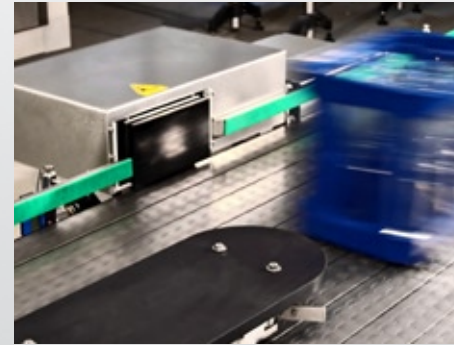

The HEUFT *maxi-flip*



The HEUFT *xtray*

The HEUFT *rejector*

The following rejection systems can be used with the HEUFT LGX crate check:

The HEUFT *xtray*

- rejection of cases
- minimum maintenance and space required
- no conversion work required for a brand change

The HEUFT *maxi-laner*

- rejection of cases onto parallel conveyor chains
- particularly smooth transversal acceleration of the containers
- no conversion work required for a brand change
- a load-dependent control system indirectly weighs each crate and calculates the rejection force required

The HEUFT *maxi-flip*

- extremely precise system for the rejection of cases onto parallel conveyor chains
- load-dependent control system
- minimum wear and tear
- no conversion work required for a brand change
- minimum maintenance and space required





The HEUFT SX



The HEUFT InLine



The HEUFT VGX

Other HEUFT products



The following products may also be of interest to you:

The HEUFT SX

- sorts returnable glass and PET bottles
- up to 72,000 bottles per hour
- ensures an unmixed container flow
- compact construction, minimum space required

The HEUFT InLine

- empty bottle inspection of the highest standard
- minimum space required due to linear transport
- optimal detection quality due to tailored hardware and software
- minimum false rejection rate

The HEUFT VGX

- quality control for full cases
- precise, reproducible brand adjustments
- transport speed up to 1 m/s
- for all types of cases used by the drinks industry



CONTACT DETAILS

HEUFT SYSTEMTECHNIK GMBH

Burgbrohl, GERMANY
Phone: +49 2636 56 0
info@heuft.com

HEUFT LTD.

Tamworth, GREAT BRITAIN
Phone: +44 1 827 25 5800
uk@heuft.com

HEUFT HISPANIA, S.A.

Madrid, SPAIN
Phone: +34 91 6667 300
spain@heuft.com

HEUFT QUALIPLUS B.V.

Deventer, NETHERLANDS
Phone: + 31 570 6617 00
netherlands@heuft.com

HEUFT FRANCE S.A.

Brumath, FRANCE
Phone: +33 388 59 3000
france@heuft.com

HEUFT ITALIA s.r.l.

Vigevano, ITALY
Phone: +39 0381 290411
italy@heuft.com

HEUFT SCAN Aps

Gilleleje, DENMARK
Phone: +45 4836 5070
scandinavia@heuft.com

HEUFT USA Inc.

Downers Grove, USA
Phone: +1 630 968 9011
usa@heuft.com

HEUFT DO BRASIL Ltda.

Alphaville-Barueri-SP-BRASIL
Phone: +55 11 4195 7671
brasil@heuft.com

HEUFT S.A.

Beccar, ARGENTINA
Phone: +54 11 4707 0936
argentina@heuft.com

HEUFT MEXICO S.A. de C.V.

Naucalpan de Juárez, MEXICO
Phone: +52 55 5374 3280
mexico@heuft.com

HEUFT Systems Technology Co., Ltd.

Shanghai, CHINA
Phone: +86 21 6434 3911
china@heuft.com

HEUFT ASIA LTD

Hong Kong, CHINA
Phone: +86 21 6434 3911
asia@heuft.com

HEUFT AUSTRIA GMBH

Leobersdorf, AUSTRIA
Phone: +43 2256 65556 0
austria@heuft.com

OOO HEUFT EURASIA

Moscow, RUSSIA
Phone: +7-495-935-8704
eurasia@heuft.com

INTERNET:

www.heuft.com
E-MAIL:
info@heuft.com

The HEUFT LGX returned case inspection

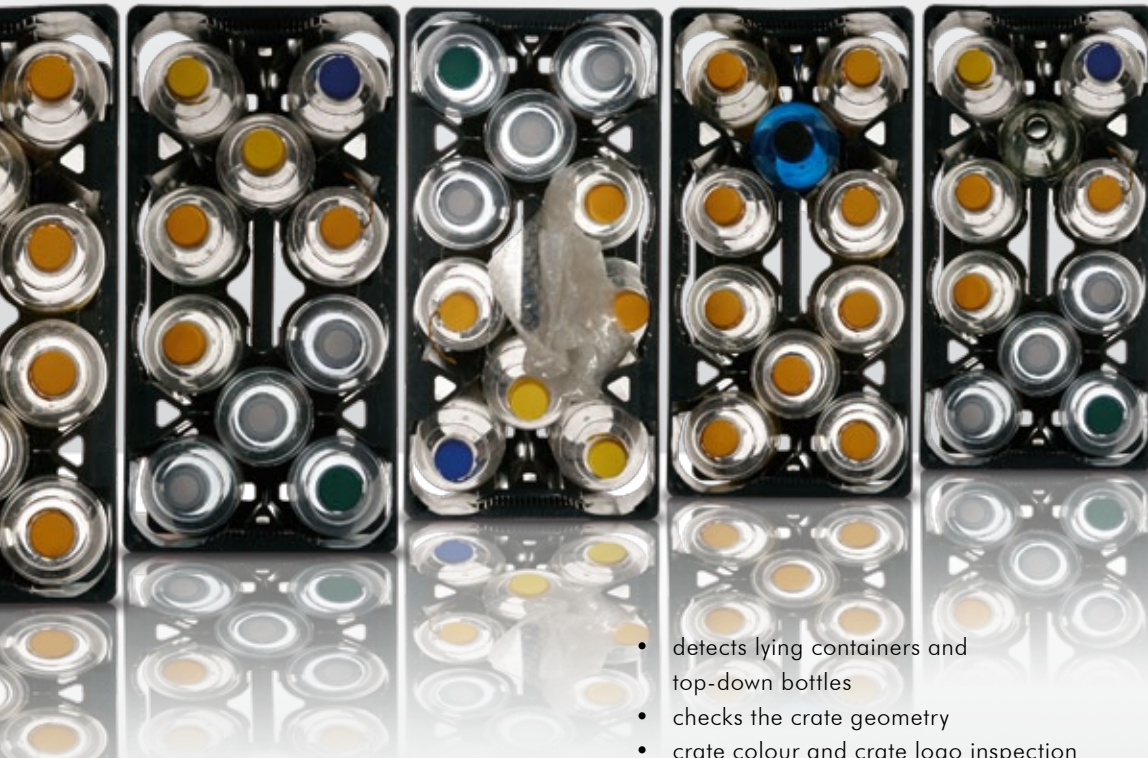

FUNCTIONS

- detects bottles which are too tall, too short or closed
- identifies neck rings on PET bottles
- foreign object detection
- bottle colour and bottle majority detection
- differentiates between glass and PET bottles

- detects lying containers and top-down bottles
- checks the crate geometry
- crate colour and crate logo inspection
- optional - complete sidewall inspection capable of learning

THE ADVANTAGES

- ensures brand purity
- detects faulty cases
- possible to set individual quality requirements

The HEUFT *reflex* image processing system for the highest inspection quality with a minimum false rejection rate
[more]*

Combined evaluation of the measurements by means of fuzzy logic
[more]*

Very hygienic due to open construction - low-maintenance design
[more]*

Identification of closure logos, neck rings, swing top bottles, bottle heights and colours
[more]*

Crate logo and colour detection
[more]*

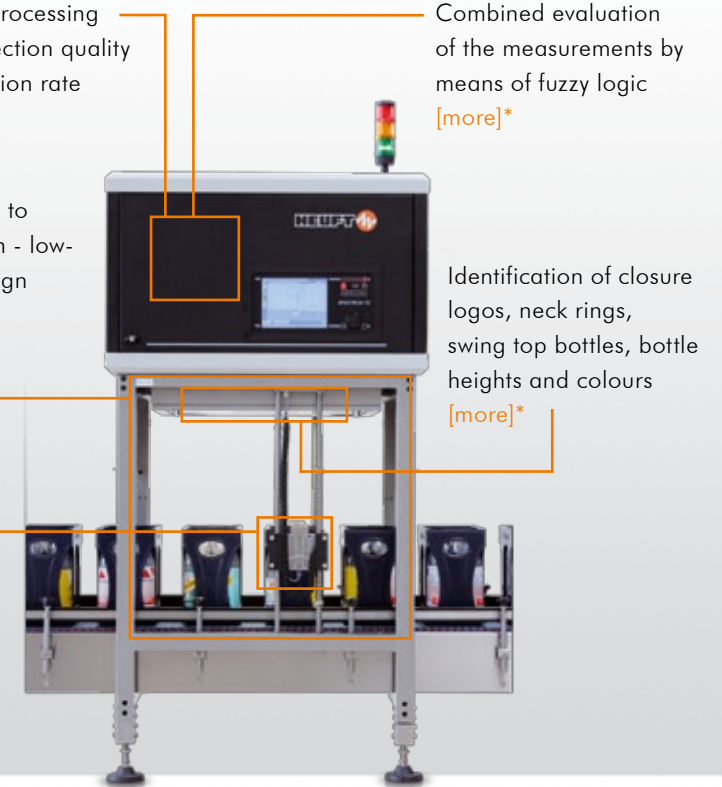

- fully automatic brand changeover
- modular construction upgradable at any time
- integrated future-proof network interface (Industrial Ethernet and TCP / IP)
- remote service connection via the Internet and the SQL / DDE database interface
- high processing speed, conveyor speed up to 1 m/s

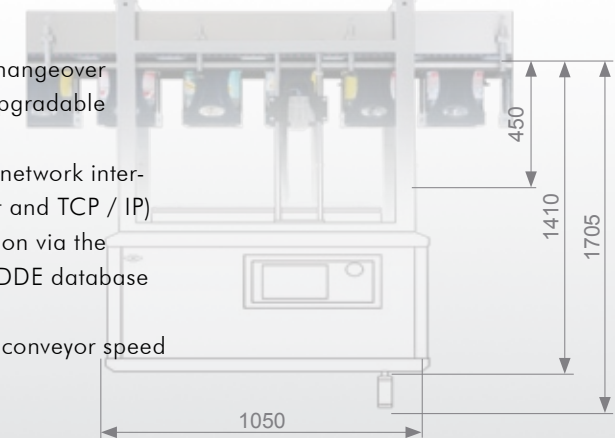

* [more] detailed information on www.heuft.com/lx

